



Operational Guidelines for Home Composting



Table of Contents

Abbreviations	4
Glossary.....	5
CHAPTER -1: INTRODUCTION TO HOME COMPOSTING	7
Background 7	
1.1. What is home composting?	7
1.2. Benefits of home composting	7
1.3. Methods for home Composting	8
1.3.1. Methods for composting at Household level	8
1.3.2. Methods for composting at Community level	14
1.4. Dos and Don'ts of Composting	18
1.4.1. What to compost?	18
1.4.2. How composting works? How to control it?	19
1.4.3. Composting period	19
1.5. Frequently occurring issues and their solutions	20
1.6. Use of home compost	20
CHAPTER – 2: IMPLEMENTATION STRATEGY.....	22
2.1. Step by Step Action Plan for implementation	22
2.1.1. Setting up a formal Institutional Structure for implementation and monitoring	22
2.2. Awareness generation	22
2.3. Identification of units for implementation of home composting	23
2.4. Training and Capacity building	24
2.4.1. Training of the Municipalities/ Municipal Corporations officials	24
2.4.2. Training of the unit owners/managers	24
2.4.3. Training of SLF and SHG members	25
2.5. Forging Partnerships at Local Level	25
2.6. Roles and Responsibilities of monitoring cell at state and Municipalities/ Municipal Corporations level	25
2.6.1. State home composting cell	25
2.6.2. Home Composting Cell at Municipalities/ Municipal Corporations level	25
2.7. Monitoring and Reporting	26
Annexures	27
Annexure 1 – Estimated Carbon: Nitrogen Ratio for compostable items	27

List of Tables

Table 1: Summary matrix of different technologies	18
Table 2: Frequently occurring issues in composting with their solutions	20
Table 3: Roles and Responsibilities of Municipalities/ Municipal Corporations functionaries	26

List of Figures

Figure 1: Specifications of Pit Composting.....	9
Figure 2: Specifications of Pot composting.....	10
Figure 3: Specifications of Khamba or 3 vessel composting	11
Figure 4: Specifications of Kitchen Bin Composting.....	12
Figure 5: Specifications of Mose Pit Composting.....	13
Figure 6: Specifications of rotary drum composting.....	14
Figure 7: Specifications of Drum Composting.....	15
Figure 8: Image of Steel Mesh Composter.....	17

Abbreviations

BWGs	Bulk Waste Generators
CDMA	Commissioner and Director of Municipal Administration
C/N ratio	Carbon-Nitrogen ratio
CRPs	Community Resource Persons
CSR	Corporate Social Responsibility
GHG	Green House Gas
HHs	Households
IEC	Information Education and Communication
MA & UD	Municipal Administration & Urban Development
MD	Mission Director
MEPMA	Mission for Elimination of Poverty in Municipal Areas
MoEF&CC	Ministry of Environment, Forest and Climate Change
MoHUA	Ministry of Housing and Urban Affairs
NGO	Non-Governmental Organisations
OWC	Organic Waste Composter
RWAs	Residential Welfare Associations
SBM	Swachh Bharat Mission
SBM-U	Swachh Bharat Mission - Urban
SHGs	Self Help Groups
SMC	State Mission Coordinator, MEPMA
SLFs	Slum Level Federations
TLFs	Town Level Federations
ToT	Training of Trainers

Glossary

Anaerobic Process: The controlled process involving microbial decomposition of organic matter in absence of oxygen.

Bund: A small dam like structure built around the pit to avoid water from entering into the pit.

Bulk Waste Generators: Bulk waste generators includes residential and non-residential such as buildings occupied by the central government departments or undertakings, state government departments or undertakings, local bodies, public sector undertakings or private companies, hospitals, nursing homes, schools, colleges, universities, other educational institutions, hostels, hotels, commercial establishments, markets, places of worship, stadia and sports complexes having an average waste generation rate exceeding 100kg per day.

Compost Mart: The compost mart is the place where material and equipment needed for composting is made available.

Compost Pile: A pile of green and brown refuse from kitchen/ garden which decomposes to produce compost.

Composting: The controlled process involving microbial decomposition of organic matter

Curing of Compost: Giving time to the compost to stabilize. Uncured compost may be harmful to the plants.

Dry waste: The waste other than biodegradable waste and inert street sweepings, and includes recyclable and non-recyclable waste, combustible waste, sanitary napkins, diaper, etc.

Landfills: Safe disposal of inert residual waste at sanitary landfills after recycling and reuse to maximum extent possible.

Leachate: Liquid that seeped through solid waste or other medium and which has extended soluble or suspended matter from it.

Processing: The scientific process by which segregated solid waste is handled for the purpose of reuse, recycling or transformation into new products.

Recover: The process of recovering the material from solid waste or mixed waste

Recycle: The process of transforming segregated non-biodegradable solid waste into new material or product or as raw material for producing new products which may or not be similar to the original products.

Reduce: Minimization of amount of waste that is generated.

Reuse The reuse of products for multiple times or using it for different purpose from what it originally intended.

Segregation: Sorting of waste into various components of solid waste namely biodegradable

wastes including agriculture and dairy waste, non-biodegradable wastes including recyclable waste, non-recyclable combustible waste, sanitary waste and non-recyclable inert waste, domestic hazardous wastes, and construction and demolition wastes

Solid Waste: Solid waste includes domestic waste, sanitary waste, commercial waste, institutional waste, catering and market waste and other non-residential wastes, street sweepings, silt removed or collected from the surface drains, horticulture waste, agriculture and dairy waste, treated bio-medical waste excluding industrial waste, bio-medical waste and e-waste, battery waste, radio-active waste generated.

Waste Generator: Waste generators are the person or group of persons from residential and non-residential establishments generate solid waste.

Waste to Energy: Recovering the energy from the before its final disposal through biomethanation or incineration

Wet waste: The organic material that can be degraded by micro-organisms into simpler stable compounds.

CHAPTER -1: INTRODUCTION TO HOME COMPOSTING

Background

Unscientific management of solid waste has become a global challenge due to lack of processing facilities, open dumping, absence of a robust monitoring system, etc. To address this challenge, the Government of India launched Swachh Bharat Mission (SBM) in 2014. This laid special emphasis on improvement in the quality of life of the citizens with a focus on enhanced sanitation and creation of solid waste management infrastructure. In 2016, the Ministry of Environment, Forest and Climate Change (MOEF&CC) laid down the new solid waste management rules which makes all the waste generators responsible for segregating their waste into wet, dry and domestic hazardous waste. The rules also make the Municipalities/ Municipal Corporations responsible for encouraging the processing of biodegradable waste on the premises.

In the urban areas of Telangana, only 23% of the total waste generated is being processed. Now the State envisions to move towards scientific waste management by adopting the 4R principle – Reduce, Reuse, Recycle and Recover.

In India, 50% of the average waste generated by a citizen, accounts for wet waste which primarily includes kitchen waste and garden waste. This waste has high potential to be recycled at source and converted to high quality compost. Hence, practicing home composting could ensure source segregation of waste into dry and wet categories and moreover also avoid the unscientific disposal of wet waste into open dumping sites. Managing segregated waste in a decentralized manner has numerous benefits in terms of; reducing the requirements for transportation, reducing demand for frequent waste collection, increasing recycling efficiencies and increasing suitability of waste for processing, thus enabling efficient management of waste to form a valuable resource. As a co-benefit, adverse environmental impacts like Green House Gas (GHG) emissions and chances of spreading of disease due to likely unhealthy conditions arising from improperly managed organic waste can be heavily reduced.

1.1. What is home composting?

Home composting is a simple technique for treatment of organic waste generated in households and institutions through natural organic processes. It can be practiced by individuals without any specialized skill sets or equipment. The compost generated through this process can be used as a soil enricher in gardens, planters, etc.

The following sections of the operational guidelines highlight the benefits, methods of composting, applications of compost, the implementation strategy adopted at the State level and the monitoring mechanism.

1.2. Benefits of home composting

Composting is a great way to turn garbage into a beneficial product. Some of the benefits of composting are mentioned below:

- a. Helps individual HHs, Institution and communities to process a large portion of their waste at source and prevent wet waste from going to the landfills

- b. Reduces the collection and transportation costs
- c. Reduces the need for chemical fertilizers
- d. Eliminates uncontrolled leachate at landfills
- e. Reduces the emission of greenhouse gases from waste into the atmosphere
- f. Reduces bad smell/odour at waste collection points and roads/streets
- g. Citizens practicing home composting or community composting are more likely to use the compost themselves or develop strong off-take arrangements¹

1.3. Methods for home Composting

There are various techniques for converting waste to compost, some of which have been explained in detail hereunder. These techniques have been categorized into those which can be used by individual households and at a community level by a cluster of apartments or institutional establishments such as schools, Residential Welfare Associations (RWAs) or Bulk Waste Generators (BWGs). The details of these methods have been referenced from the “Advisory on decentralized composting and Waste to wealth - a ready reckoner for selection of technologies” published by the MoHUA.

1.3.1. Methods for composting at Household level

The techniques described for household level can be used by families of up to 6 members and would not require a lot of area or special skills.

a) Pit composting

Pit composting or trench composting is an anaerobic process of biodegrading waste directly in a pit. This process takes a longer time than other in-house composting techniques, but gives more nitrogen rich compost and is also quite easy.

Suitability

For a family of 5-6 members, pits of size 1 meter * 0.6 meter * 1 meter would be needed. The size of the pit can be modified according to the number of the family members or users. According to the MoHUA’s advisory, this technique is suitable for a maximum of 2000 kgs wet waste a day.

Infrastructural requirements

- i. Shovel
- ii. Tarpaulin/plastic sheet
- iii. Cow dung/decomposed waste and soil

¹ Advisory on On-Site and Decentralized Composting of Municipal Organic Waste

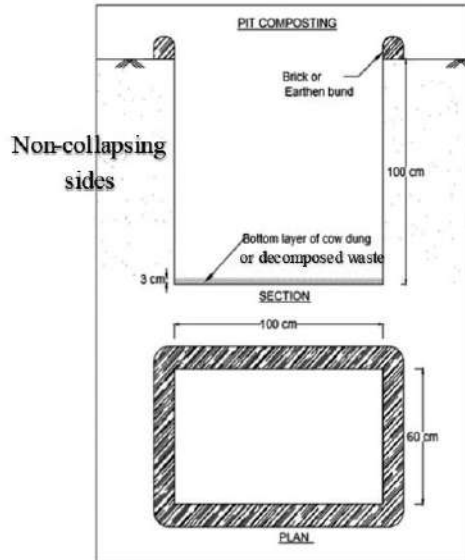

Figure 1: Specifications of Pit Composting

Composting Process

- Step 1.-** Identify an area where water doesn't get logged, and where two trenches or pits can be dug. Make a small bund around the pit to prevent the water entering the pits.
- Step 2.-** Cover the pits with the sheet to protect it from the rains.
- Step 3.-** Spread a 6-inch layer of decomposed waste or cow dung slurry.
- Step 4.-** Cut the waste into small pieces before spreading them on the layer of cow dung slurry or decomposed waste. Make sure that the waste put in is moist.
- Step 5.-** After every layer of waste, sprinkle a layer of soil to avoid any stench and prevent breeding of flies.
- Step 6.-** Continue doing this until there is about 15 cm of space in the pit.
- Step 7.-** Fill this space with soil. Leave the pit for a minimum period of 4 months.
- Step 8.-** Once the first pit is closed, use the second pit in a similar manner.
- Step 9.-** To use the compost, just dig the pit, and extract the compost. It can be directly used for soil enrichment.

Time frame – 120 to 180 days

b) Pot composting

Suitability

This composting technique works for units which produce 1 to 2 kg of biodegradable waste daily. Two mud pots, 50 cm high and having a diameter of 35 cm, are required with lid covers.

Infrastructural requirements

- i. 50 cm tall stands for holding each pot.
- ii. A plastic vessel of half liter capacity to collect the leachate
- iii. A small trowel
- iv. One painting brush
- v. 1 brick cut in 2 pieces

vi. Two plastic covers

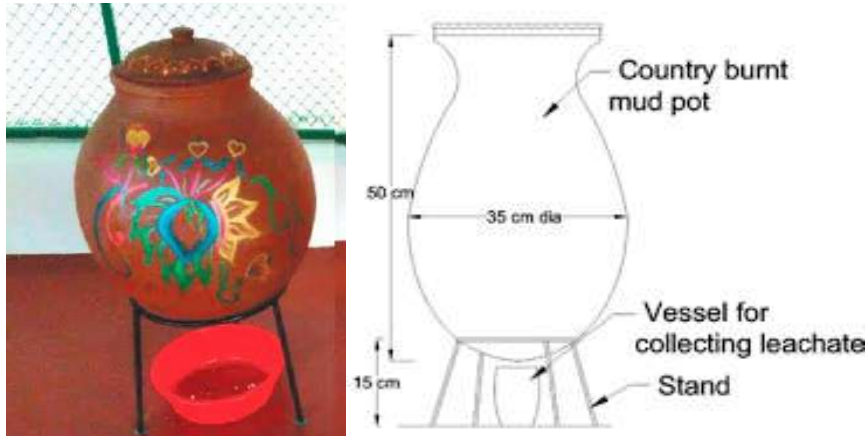

Figure 2: Specifications of Pot composting

Composting process

- Step 1.-** Make a hole in the bottom of the pot and place it at a convenient place on the top of the stand. Put the plastic container below the hole to capture the leachate.
- Step 2.-** Start putting in shredded biodegradable waste into the pot. Close the pot with the lid. And make sure to not put in more than 2 kg of waste a day.
- Step 3.-** Cover every layer of waste with compost or soil.
- Step 4.-** The waste needs to be turned thoroughly once in two days.
- Step 5.-** One week later, worms can be seen in the pot. These worms help in the composting process and will die in the next three weeks themselves. Do not try and kill them yourself.
- Step 6.-** Once the first pot is full, start using the second pot in similar fashion. By the time the second pot is filled with waste, the waste in the first one will have turned into compost.
- Step 7.-** The moisture content in the pot should be maintained. In case the quantity of water inside the pot is more, saw dust can be added to absorb the excess water.
- Step 8.-** During monsoons, cover the pots with the plastic cover and put two pieces of brick on it to prevent rainwater from entering the pot.
- Step 9.-** Sour curd or buttermilk will speed up the composting process.
- Step 10.-** Tips about leachate
 - a. Put some salt in the container collecting leachate. This will prevent the flies from hovering around.
 - b. The leachate can be diluted with water and used as compost for plants
 - c. If the flies persist, two camphor tablets should be diluted in 25 ml of oil and this oil should be applied on the pot with a brush.

Time frame - 60 to 75 days

c) Khamba/Matka/Three vessel composting

Suitability

This technique is suitable for individual households which produce up to 2 kg of biodegradable waste daily.

Infrastructural requirements

- i. 3 terracotta pots, having a height and diameter of 30 cm with lid for one pot. Pots number 1 and 2 are open from the top as well as bottom. The open part in the bottom is weaved with plastic wires. Pot number 3 is open at the top, and closed at the bottom.
- ii. Old newspapers
- iii. Hand pump/sprayer
- iv. Compost/Saw dust
- v. Steel fork

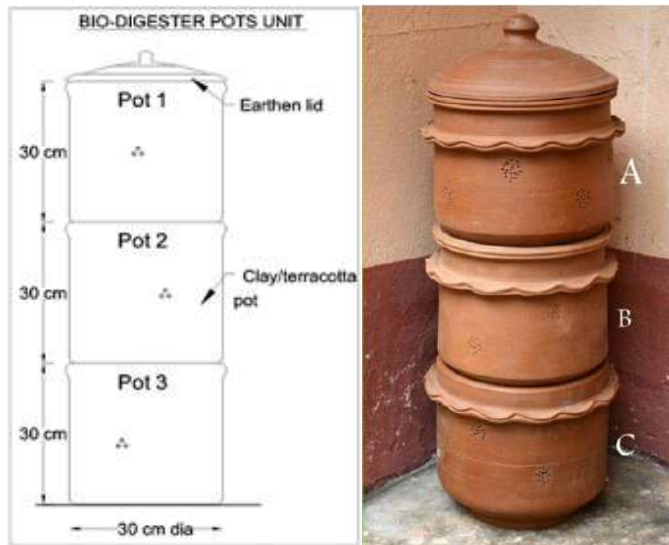

Figure 3: Specifications of Khamba or 3 vessel composting

Composting Process

- Step 1.-** Place newspaper sheets at the bottom of the pot 1 and 2 to cover the mesh wiring. This is done so that no other material other than water would seep in the pot below.
- Step 2.-** Place the pots, one on top of the other, with the pot having a closed bottom (pot 3) at the bottom of the stack.
- Step 3.-** Start adding kitchen waste to the topmost pot. Spray diluted bio culture after every layer of waste (The ratio of bio culture to water is 1:50 to make diluted bio culture).
- Step 4.-** The water used for diluting bio culture should not contain chlorine. To ensure that, the water to be used should be left open in a wide vessel for two days.
- Step 5.-** Once the topmost pot is 3/4th filled, swap the position of the pot with the middle one, and start putting in waste into pot 2.
- Step 6.-** Turn the waste every two days without tearing the newspaper at the bottom.
- Step 7.-** While the second pot is being used to collect the waste now, the composting process will shrink the material in the first pot, and it will be ready to use again when the second pot is 3/4th filled with waste.
- Step 8.-** Swap the position of pot 1 and pot 2 again. Now, pot 1 is at the top again. The waste should now be collected in this pot again, until it is filled upto 3/4th of its capacity. Then the positions will have to swapped once more.

Step 9.- Continue doing this until one of the pots is filled. Empty the contents in the bottommost pot, and continue the process until pot 3 is 3/4th filled.

Step 10.- Once that is done, sieve the contents of the last pot to get the compost. Any material that cannot be sieved can be added to the topmost pot for further decomposition.

Time frame - This process takes around 90 days.

d) Kitchen bin Composting

Suitability

Suitable for composting at a household level with 5 to 6 members.

Infrastructural requirements

One plastic bin with lid – 25 Litres

Plastic grow bags – 3 No.

One small trowel

Small fork



Figure 4: Specifications of Kitchen Bin Composting

Composting Process

Step 1.- Place the plastic grow bag inside the bin.

Step 2.- Spread starter material (saw dust treated with bio-culture) in 1 inch thick layer over the bottom as bio-platform. Either prepared bio- compost or saw dust treated with bio-culture can be used as starter material. Mix saw dust with diluted bio-culture (bio-culture water ratio 1:50) and keep it in a grow bag duly tied. After two days, saw dust mixture becomes hot by the activities of the bacteria. This hot mixture can be used as the starter.

Step 3.- Spread the shredded waste over the starter layer

Step 4.- Spray diluted bio-culture mixture over the waste. After third day, use the fork to mix the contents of old layer and new layer.

Step 5.- Repeat the procedure till the bin is filled.

Step 6.-Tie the grow bag and remove it and store it.

Step 7.-Keep the second grow bag inside the bin and continue the process.

Step 8.-Once the second bag is filled, remove it and store it. Open the first grow bag and remove the contents and start using it again. If the waste quantity is more than 2 kg/day increase the number of grow bags to give at least 20 days of storing time for filled grow bag.

Time Required – 30 to 45 days

e) Mose Pit Composting

Suitability

For a family of 5 members.

Infrastructural requirements

- i. Circular pits of required diameter and depth 1m in a convenient location – 2 Nos
- ii. Circular/ rectangular slabs to fully cover the pit, with PVC pipe of required diameter, 50cm long, vertically placed centrally on
- iii. the cover slabs - 2 sets.
- iv. PVC caps to close opening of the pipe – 2 Nos

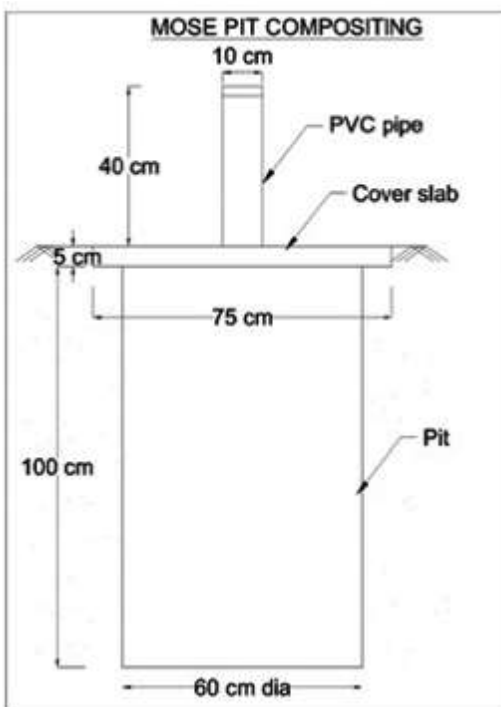

Size and specification of the infrastructure required:

- Pit of size 60cm diameter and depth 1m for a family of 5 members.
- Diameter of the pit may go up to 1.5m for institutions
- Restrict the depth to 1m in all cases as methanogenic activities get reduced at lower depth.
- The bottom of the pit is of oval shape.
- The cover slab of size 75cm diameter (for a pit of 60cm diameter) and thickness 7.5cm.
- PVC pipe of 100mm dia for domestic type and can be upto 200mm diameter for bigger size pits.

Figure 5: Specifications of Mose Pit Composting

Composting Process.

Step 1.-Ensure bacterial seeding before putting the waste into the pit by sprinkling cow-dung/ decomposed waste into the pit.

Step 2.-Drop the shredded bio-waste into the pit through the pipe opening daily and keep the pipe end closed always.

Step 3.-Pouring of warm water of 35° to 45°C temperatures once in a week will accelerate the decomposing.

Step 4.-Occasionally pouring of cow-dung mixture or any bacterial seed into the pit will be helpful.

Step 5.-Keep using the pits alternately for six months each.

Time frame - It takes about 30 to 45 days to get stabilized compost.

1.3.2. Methods for composting at Community level

Community level household techniques will be used by a group of upto 10 households.

a) Rotary Drum/In vessel composting

Suitability

Suitable for up to 10 households, daily waste intake up to 10 kg.

Infrastructural requirements

- i. A rotary drum of 250 litres capacity

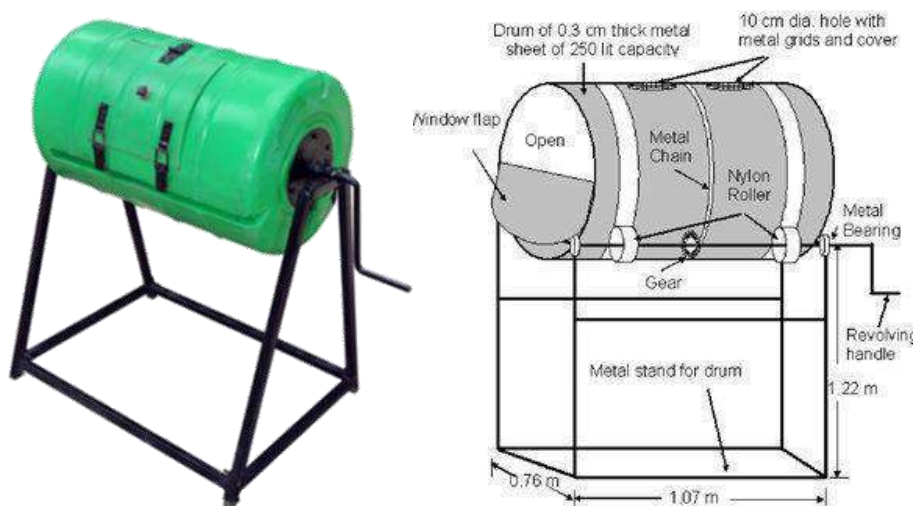

Figure 6: Specifications of rotary drum composting

Composting Process

Step 1.-The shredded waste should be added to the drum.

Step 2.-The handle of the drum is used to manually turn the waste once every day.

Step 3.-Make two to three rotations.

Step 4.-After the rotation, the half doors at the side of the drum should be opened.

Step 5.-Continue the process for 15 days.

Time frame - It takes about 15 to 20 days to get stabilized compost.

b) Drum Composting

Suitability

The technique of drum composting would work for 10-15 households.

Infrastructural requirements

- i. 2 drums of 50 liters each
- ii. A pedestal for the drum
- iii. A tap
- iv. Plastic vessel of 5-liter capacity
- v. Plastic net bags
- vi. Two bricks
- vii. Gloves

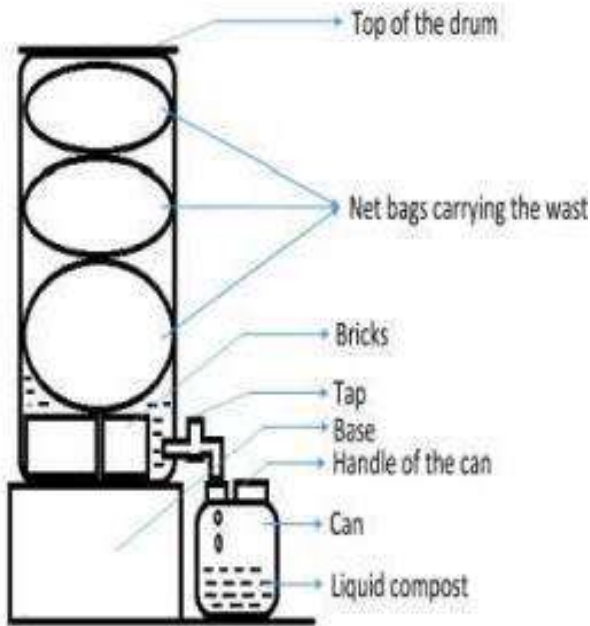

Figure 7: Specifications of Drum Composting

Composting process

- Step 1.-** Take a plastic drum and fix the tap on the bottom of the drum.
- Step 2.-** Place this drum on a pedestal of suitable height to accommodate the plastic vessel below the tap.
- Step 3.-** Prepare the liquid culture by mixing an adequate amount of bio-culture in water (For treating 80-100 kg of waste, mix 250 ml of culture in 3 liters of water).
- Step 4.-** Segregate the waste and keep the waste which can be converted into compost in the net bags. Do not put papers or materials which can be further used after recycling.
- Step 5.-** In a large container, mix the waste with the prepared culture solution by wearing gloves in the hands.
- Step 6.-** Put some bricks inside the drum in such a way that the bags carrying the waste do not block the tap (refer image).
- Step 7.-** After mixing the waste with the solution, put the waste in the plastic net bags and tie a knot by the plastic rope when it gets filled.
- Step 8.-** Put the plastic net bags in the drum. Continue this process until the drum gets filled.

Step 9.- Pour the remaining leftover solution of the container into the drum from the top and close the lid of the drum.

Step 10.- Connect a pipe from the tap of the drum to the plastic can.

Step 11.- Open the tap for collection of liquid.

Step 12.- Pour back the liquid collected till the third day back in the drum through the top, after opening the lid. Also, when the drum is opened on the third day, see whether the compost is uniformly converting or not. If not, then add more liquid solution (250ml culture mixed with 3 litres of water) to it.

Step 13.- Put the can beneath the tap after pouring the liquid for collection of liquid compost.

Step 14.- Whenever during the composting, if the process starts to smell then add some more culture (mixed with water) to it from the top of the drum. Increase in foul smell is an indication that composting is not going properly.

Step 15.- On the 20th day of composting, take out all the net bags from the drum and spread the contents of the net bag on the ground to dry.

Step 16.- The liquid left inside the drum is also the liquid compost, so collect it in the can.

Step 17.- After drying the solid waste for 2 days, sift it with a sieve. The collected solid is the solid compost.

Time frame - This technique is one of the fastest ones to convert waste into compost. One composting cycle usually takes 15-25 days.

c) Organic Waste Composter (OWC)

Suitability

This technique is great for institutions or a large number of apartments. The waste processing capacity of a mechanized OWC range from 100 kgs a day to 5000 kgs of wet waste a day.

Infrastructural requirements

- i. Space requirement – 100 sq. meter to 500 sq. meter depending on the capacity of the OWC.
- ii. A shed/designated space for the OWC
- iii. Old compost/soil
- iv. Culture
- v. Plastic racks for curing of compost

Composting process

Step 1.- Shred the biodegradable waste into small pieces before putting it in the OWC.

Step 2.- Add culture and old compost to the waste.

Step 3.- Switch on the OWC, and the compost can be collected after 24 hours.

Step 4.- The compost should be collected in the racks, and left for a few days to cure it. During curing, water should be sparsely sprayed to retain the required moisture.

Step 5.- The compost can then be used in the garden.

Time frame

It takes 24 hours for the OWC to convert the waste into compost. However, this compost should be cured for some days before using it. Put the compost in plastic crates, and leave it for at least a week (longer the curing period, better is the quality of the compost). During this time, keep the compost slightly moist.

d) Steel Mesh Composter

Suitability

One unit has the capacity to hold waste of 50 kg per day. Thus, this technique works in case of a cluster of houses. If the number of houses is more, the number of units for composting can be increased.

Infrastructural requirements

- i. Space requirement – 500 sq. meter
- ii. A shed/designated space for the composter
- iii. Cement slabs
- iv. Steel mesh plate for the top (should be equal to the size of the compost)
- v. Steel mesh ring (to install inside the composter).
- vi. Saw dust



Figure 8: Image of Steel Mesh Composter

Composting process

Step 1.- Put together a square-shaped platform using a few cement slabs.

Step 2.- Leave some gap between each slab so that leachate, if any, drips down easily.

Step 3.- Place a steel mesh plate on top of the slabs to prevent entry of rodents from the bottom.

Step 4.- Make a steel mesh ring of 3 ft diameter and 2.5 ft height (open cylinder).

Step 5.- Place this ring on the platform.

Step 6.- Wrap the ring with gunny sack to avoid the contents from spilling out and messing up the surroundings.

Step 7.- This also prevents rodents from digging into the piles.

Step 8.- Collect the segregated kitchen waste.

Step 9.- Sprinkle little bit of saw dust on it to absorb excess moisture.

Step 10.- Spread a thick layer of (at least 8-10 inches) dry leaves at the bottom of the composter.

Step 11.- This absorbs the moisture content seeping down from the top layers.

Step 12.- Add the bio degradable waste and dry leaves to the composter in alternative layers.

Step 13.- The top portion is always filled with dry leaves to avoid flies, odour, mosquitoes and rodents.

Step 14.- Leave the composter for about 15-20 days. Churn the waste after 15 days.

Step 15.- Afterwards remove and lay it for maturing for another 30 days.

Step 16.- After a total of about 45 days, the compost is ready. Sieve it and store it for consumption.

Step 17.- Bigger and not fully composted parts sieved out are once again added to the composter for composting.

Step 18.- Keep the place tidy and ensure that it is airy and covered (to save from sun and rain).

Time frame

It takes about 30 days for the compost to be made from waste. Additional time (of one month) required to cure the compost.

Table 1: Summary matrix of different technologies

Method	Suitability	Quantity of waste input (per day)	Type of process	Time frame
Composting methods for individual household units				
Pit Composting	For a family of 5-6 members	Maximum 2000 kgs	Easy	120 – 180 days
Pot Composting	Units which generated 1 to 2 Kgs of waste daily	1 to 2 Kgs	Easy	60 – 75 days
Khamba/Matka/Three vessel composting	Individual HHs	2 kgs	Easy	Around 90 days
Kitchen bin Composting	Individual HHs	2 kgs	Moderately easy	60 – 75 days
Mose Pit Composting	Individual HHs	0.7 kgs	Difficult	30 – 45 days
Composting methods for communities, institutional establishments/BWGs				
Rotary Drum/In vessel composting	Upto 10 HHs	Daily waste intake upto 10Kgs	Easy	15 to 20 days
Drum Composting	10 – 15 HHs	80 – 100 Kgs of waste	Moderately easy	22 to 25 days
Organic Waste Composter (OWC)	Large number of apartments and institutions	100 – 5000 kgs	Easy	24 Hours and the collected compost from OWC shall be cured for a few days
Steel Mesh Composter	Cluster of houses	50 kgs	Difficult	

Type of process: Ranges from easy to difficult based on how complex the implementation of the technique is.

1.4. Dos and Don'ts of Composting

1.4.1. What to compost?

It is very important to understand that certain items are kept out of composting. While selecting materials for your compost, avoid waste that attracts pests and diseases /insect ridden plants.

Table 1: Types of wet waste to be added in the compost

What's In		What's Out
Greens	Browns	
Vegetable peelings	Corn stalks	Cooked food that may become moldy
Rotten fruit	Newspaper (Shredded)	Fatty food items
Coffee grounds	Leaves	Leftover meat, cheese
Tea leaves	Bark	Chemically treated fruit skins
Manure from herbivorous pets/animals	Straw	Fish and bones
Egg shells	Wood chips	Plastic material
Tea bags	Unprocessed cartons/ cardboards (should be shredded)	Dairy products
Paper towels and napkins		Ash from barbecues or coal
Yard/Grass trimmings		Cartons and cardboard with plastic film, paper napkins used with chemical based cleaner
		Straws, stirrers and twist ties
		Metal
		Toxic chemical material

1.4.2. How composting works? How to control it?

Composting is a method of recycling the organic waste in controlled aerobic conditions. During this process the microorganisms break down the organic matter into simpler substances. There are various factors which influence the composting process like air, temperature, moisture, etc. which are explained below:

- a. **Temperature:** Maintaining proper temperature enables the microbes to cultivate faster and allows the destruction of weed seeds, fly larvae and plant pathogens. The rise in temperature in the system is an indication of prime performance. When the temperature at the top starts to decline, the pile should be turned and mixed to allow aeration into the compost. It is ideal to maintain temperature ranging between 55°C to 68°C.
- b. **Moisture:** Maintaining adequate moisture in the composting system is key for better performance. The ideal moisture for best performance is 45%. Excess moisture could cause the pile to go anaerobic and emit foul odour.
- c. **Carbon-Nitrogen Ratio (C/N):** C/N ratio primarily controls the rate of decomposition of organic waste. To maintain proper C/N ratio, 3 parts of green waste should be mixed with one part of browns.

1.4.3. Composting period

The composting period depends on several factors like temperature, moisture, air, particle size, C/N ratio, etc. The number of times the mixture is turned also has an impact on the microbial activities inside the system. Usually the compost produced from home composting techniques shall take around 4-6 weeks, but this may vary as per the technology adopted.

1.5. Frequently occurring issues and their solutions

During the process, there are several changes we notice such as:

- The pile will shrink as the microbes decompose the organic material
- The temperature will drop
- The material initially used for composting will no longer remain the same
- After a month or more, once the temperature drops the compost is ready to use.

Turning an active compost pile by mixing proper materials with adequate aeration and proper moisture is an important step in the composting process. Sometimes it is also important to rectify the problems caused during the process. Some of them are as given below:

Table 2: Frequently occurring issues in composting with their solutions

Issue	Possible Cause	Solution
Pile is wet and stinky	<ul style="list-style-type: none"> • Excess moisture • Compaction 	<ul style="list-style-type: none"> • Add brown material • Turn Pile • Place scraps at the center of the pile
Pile is dry	<ul style="list-style-type: none"> • Too much brown material • Too little water 	<ul style="list-style-type: none"> • Add fresh kitchen scraps • Moisten with water • Cover pile to reduce evaporation
Pile is cold	<ul style="list-style-type: none"> • Too much nitrogen 	<ul style="list-style-type: none"> • Add green materials such as grass clippings & kitchen scraps
Pile attracting pests	<ul style="list-style-type: none"> • Inappropriate materials added and poor covering 	<ul style="list-style-type: none"> • Adding of grease, oils, meats, breads, etc. (refer do's and don'ts) shall be avoided • Add soil or brown material to cover food scraps • Put kitchen scraps in the center of the pile
Low temperature	<ul style="list-style-type: none"> • Pile too small • Too little moisture • Poor aeration 	<ul style="list-style-type: none"> • Increase pile • Add water and turn pile • Turn pile
Pile attracting flies	<ul style="list-style-type: none"> • Improper covering of food scraps 	<ul style="list-style-type: none"> • Cover green material with browns • Place kitchen scraps in the center of the pile

1.6. Use of home compost

Identification of good compost is done by its color and smell. It is said to be good when it is dark brown to black in color, crumbly to touch and does not stink. It should be finely granular, such that 90% of it can be sifted by a 0.4mm sieve.

The individual households can use this compost for potted plants, or gardens. If during the process, any leachate is generated, that too can be diluted with water and used as a compost.

When the compost is generated at a community level, the users can distribute the compost amongst themselves, or choose to use it for a common green space. Alternatively, if none of the users have plants, they can sell the compost, and decide to distribute the revenue.

Institutional establishments such as schools, halls, BWGs may also choose to store and use the compost or sell it in the market. If the compost is to be sold in the market, lab tests could be undertaken to ensure

that the compost made meets the required standards as prescribed by the MoHUA, Government of India (Annexure 2).

CHAPTER – 2: IMPLEMENTATION STRATEGY

2.1. Step by Step Action Plan for implementation

2.1.1. Setting up a formal Institutional Structure for implementation and monitoring

The implementation of home composting activity in the state will be led by a home composting cell comprising of:

1. Deputy Director, CDMA
2. Solid Waste Management (SWM Expert), SBM department
3. State Mission Coordinator (SMC), MEPMA
4. Compost Development Officer (CDO), CDMA

Municipal Commissioner of Municipalities/Municipal Corporations will be designated as nodal officer for implementation of the program. The home composting cell shall be formed at the Municipalities/ Municipal Corporations level for monitoring and implementation of the program and will be responsible for hosting regular review meetings and also be used as a helpdesk for any citizens who may be interested in initiating home composting. The home composting cell will have the following members.

For Municipal Corporations	For Municipalities
1. Municipal Commissioner	1. Municipal Commissioner
2. Chief Medical Health Officer	2. Town Mission Coordinator
3. Environmental Engineer	3. Environmental Engineer
4. Town Mission Coordinator	4. Sanitary Inspector/ Sanitary Supervisor
5. Sanitary Inspector /Sanitary Supervisor	5. Community Organizer/ Resource Person
6. Community Organizer/ Resource Person	

The Sanitary inspector and Community Organizer/Resource Person will be monitoring the implementers, i.e., the CRPs/SLFs/TLFs. They may seek support from the Horticultural officer for technical guidance and facilitating tie-ups with the nurseries for onsite composting. The CRPs and sanitary inspectors shall report to the Municipal commissioner on a daily basis. Moreover, the cell shall review the progress and report to the State home composting cell on a weekly basis or at a frequency as prescribed by the State home composting cell. The reporting shall be done through a monitoring tool which is being developed by the State or in the format as prescribed the State home composting cell.

2.2. Awareness generation

The state shall conduct Training of Trainers (ToT) for Community Resource Persons (CRPs) on home composting and create a pool of master trainers. With support from Municipalities/ Municipal Corporation Officials, CRPs will sensitize RWAs, general public on segregation and composting procedures through multiple channels (digital, broadcast, print or audio content) for communication, learning and stakeholder engagement. Awareness activities will include methods for home composting, benefits and solutions for issues associated with it.

At Municipalities/ Municipal Corporations level:

- The Municipalities/ Municipal Corporations shall conduct awareness generation programs at ward level through audio or visual communication.
- Using print media to create better awareness to the citizens for a better understanding.
- CRPs shall train SLFs on home composting during monthly meetings.
- The cities can demonstrate the technologies in places which witness a high footfall of the citizens. The technologies can have either a display board or audio tools explaining the steps, benefits, etc. of on-site composting.

The state may utilize the SBM IEC funds for various awareness generation activities for implementing home composting activities. The nominated CRPs shall be paid at a fixed rate of Rs.150/- per each dwelling unit/ flat (Gated communities/Apartments) and Rs.250/- per each commercial establishment (Hotels/restaurants and etc). The payment shall be done for at least six (6) months. The expenditure towards the above activity can be met from the SBM funds.

2.3. Identification of units for implementation of home composting

The Municipalities/ Municipal Corporations will be responsible for identifying the potential units (Apartments, Gated Communities, Hotels, Individual Households etc.) in their jurisdiction for implementing home composting. These units should be a mix of individual households, RWAs, institutional establishments and BWGs. The Municipalities/ Municipal Corporations can choose to implement the action plan in a phased manner. However, the objective should be to start with a minimum of 10% of the total households of the Municipalities/ Municipal Corporations. If the Municipalities/ Municipal Corporations has BWGs, 50% of the BWGs should be targeted in the first phase.

Carrying out composting at a decentralized level requires time and efforts from the owners and some dedicated space. Hence while shortlisting the units, there are certain parameters that would need to be considered:

- i. The unit owners/managers should show willingness to implement composting in their establishment.
- ii. Individual household units should have potted indoor/outdoor plants in absence of a garden.
- iii. For units except individual households, there should be a caretaker to oversee and maintain the composting unit.

The Municipalities/ Municipal Corporations should follow the state target orders to identify the number of units.

Models of Engagement of SHGs in implementation

Once the Municipalities/ Municipal Corporations finalise the timeline for implementation strategy, the next step would be decided the implementers.:

- i. **Implementation through CRPs:** The CRPs will be responsible for generating awareness about composting, and for identification of the units where the composting process will be implemented. The CRPs will have to guide the unit owners/managers on the technology best suited, and provide handholding

support at least for the first composting cycle. Each Municipalities/ Municipal Corporations can decide the number of CRPs required based on how many units have opted for on-site processing.

ii. **Implementation through SLFs:** The Municipalities/ Municipal Corporations can also engage the SLFs in the implementation process. Interested SLF members may be identified in each ward, and the responsibilities would include training and helping the units in selecting a suitable composting technique and helping them start the composting process by handholding wherever necessary. The SLFs will be trained by the master trainers. Engaging SLF will help the Municipalities/ Municipal Corporations to reach a larger audience.

iii. **Setting up Compost marts:** The Municipalities/ Municipal Corporation may also decide to initiate a compost mart, similar to the sanitation mart. The objective of the compost mart is to make available all the equipment that may be needed for composting and guide the buyers about the use of each product. This mart can be run and managed by SHG members, and can also be converged with the ongoing SHG initiatives such as sanitary mart or the development of nurseries.

2.4. Training and Capacity building

2.4.1. Training of the Municipalities/ Municipal Corporations officials

The CRPs from the Municipalities/ Municipal Corporations shall be the key persons for overseeing the implementation of home composting in their cities along with the nodal person appointed for SBM- U.

Each Municipalities/ Municipal Corporations shall nominate CRPs and other municipal functionaries (as given in 2.1.1) for ToT on home composting which shall be conducted in batches by the State. The training shall include the basics of home composting, various technologies, identification of units for the pilot implementation, the monitoring process to be followed, reporting mechanism, etc. Moreover, at the City level, a training program shall also be conducted for the SLFs and TLFs for awareness generation in their communities and wards. This would help in reaching out to more people in less time.

The CRPs will also be in charge of imparting the training to the SLF/SHG members if a certain Municipalities/ Municipal Corporation decides to launch a compost mart. Training would include aspects of sourcing the equipment, negotiation, customer dealing, managing the store accounts and other soft skills required.

2.4.2. Training of the unit owners/managers

Each Municipalities/ Municipal Corporations shall organize a training for the unit owners/managers on various composting technologies, the steps to be followed, the precautionary measures for composting, etc. The CRPs and nodal officers from the SBM-U department shall be responsible for preparing a training calendar and imparting these training based on the training material provided by the State. The CRPs will also be responsible for training the unit wners/managers based on the implementation model chosen.

The Municipalities/ Municipal Corporations may also choose to do hands-on training for demonstration of the composting process.

2.4.3. Training of SLF and SHG members

SLF members interested in engaging with the implementation of the home composting shall have to undergo a training on generation of awareness amongst the people, the various methods of composting, the equipment that would be needed, the food that can or cannot be composted etc. The SLF members will be trained by the CRPs and shall be responsible for attending all the training sessions organized by the CRPs and/or nodal officer.

SHGs that may be interested in getting involved with the compost marts shall also have to undergo training comprising topics related to owning and running a store and details about the composting.

2.5. Forging Partnerships at Local Level

The Municipalities/ Municipal Corporations shall explore partnerships with private organizations, Non-Governmental Organizations (NGOs), etc. working at a local level for technical and financial assistance to roll out the home composting initiative. The Corporate Social Responsibility (CSR) initiatives of private organizations could be instrumental in providing funding for the equipment/infrastructure required for the composting technology. The Municipalities/ Municipal Corporations can also partner with technical institutions or agricultural universities to assist in training and implementation in the city.

2.6. Roles and Responsibilities of monitoring cell at state and Municipalities/ Municipal Corporations level

2.6.1. State home composting cell

- Issues an advisory to identify the units for implementing the home composting
- Coordinates with Municipalities/ Municipal Corporations in identification of CRPs for monitoring home composting activities
- Conducts ToT for Municipalities/ Municipal Corporations functionaries and CRPs on awareness generation, implementation plan and monitoring activities
- Finalization of strategies for implementation
- Conducts regular meetings and review the progress of phase wise implementation of home composting activities in Municipalities/ Municipal Corporations
- Monitors the performance of Municipalities/ Municipal Corporations

2.6.2. Home Composting Cell at Municipalities/ Municipal Corporations level

- Municipalities/ Municipal Corporations are responsible to prepare phase wise implementation plan
- Finalizing the models for implementation
- Identification of CRPs/masters trainers for conducting trainings at ward level
- Monitors the performance of master trainers and conducts regular review meetings

The home composting initiative is being implemented under the joint efforts for MEPMA and SBM-U, Telangana. The broad roles and responsibilities of various Municipal/ Municipal Corporation functionaries are summarized as follows:

Table 3: Roles and Responsibilities of Municipalities/ Municipal Corporations functionaries

SL. No.	Roles and Responsibilities	Home composting cell	SHGs/CRPs
1	Identification of CRPs for promoting home composting		
2	Provide the IEC materials for city wide awareness generation		
2	Generating city wide awareness for home composting		
3	Identification of units for implementation		
4	Conducting training of the unit owners and managers through the standard training material provided by the State		
5	Conduct training of SLFs and TLFs for awareness generation in their respective wards		
6	Regular scheduled visits to the units practicing home composting and liaising with the unit owners		
7	Providing technical guidance to the CRPs as and when required		
8	Reporting the progress of the on-ground activities to the State level through live updates on the State level monitoring tool		
9	Ensuring regular payments to the CRPs within 7 days of the next month.		
10	Provide ID cards to the CRPs		
11	Supervise the work of CRPs on a regular basis		
12	Conduct meetings with the SHGs/CRPs for resolving the field level issues and reviewing the progress		

2.7. Monitoring and Reporting

The home composting cell shall monitor the daily progress in the number of units implementing home composting, the composting process followed by them, the issues faced by them, etc. as per the directive of the State Government. For better monitoring and transparency of information, a monitoring tool shall be developed by the State. This tool shall help in live tracking of the activities being implemented on the ground. It will enable the state, district as well as the city to identify the gaps and make informed decisions.

Annexures

Annexure 1 – Estimated Carbon: Nitrogen Ratio for compostable items

Estimated Carbon-to-Nitrogen Ratios	
Browns = High Carbon	Carbon: Nitrogen
Ashes, wood	25:1
Cardboard, shredded	350:1
Corn stalks	75:1
Fruit waste	35:1
Leaves	60:1
Newspaper, shredded	175:1
Peanut shells	35:1
Pine needles	80:1
Sawdust	325:1
Straw	75:1
Wood chips	400:1
Greens = High Nitrogen	Carbon : Nitrogen
Alfalfa	12:1
Clover	23:1
Coffee grounds	20:1
Food waste	20:1
Garden waste	30:1
Grass clippings	20:1
Hay	25:1
Manures	15:1
Seaweed	19:1
Vegetable scraps	25:1
Weeds	30:1

Source: Planet Natural Research Centre

Annexure 2 – Compost Quality Standards

Sl. No.	Parametres	Organic Compost FCO 2009	Phosphate Rich Organic Manure FCO (PROM) 2013
1.	Arsenic (mg/kg)	10.00	10.00
2.	Cadmium (mg/kg)	5.00	5.00
3.	Chromium (mg/kg)	50.00	50.00
4.	Copper (mg/kg)	300.00	300.00
5.	Lead (mg/kg)	100.00	100.00
6.	Mercury (mg/kg)	0.15	0.15
7.	Nickel (mg/kg)	50.00	50.00
8.	Zinc (mg/kg)	1000.00	1000.00
9.	C/N ratio	<20	less than 20:1
10.	pH	6.5 - 7.5	(1:5 solution) maximum 6.7
11.	Moisture, % by weight, maximum	15.0-25.0	25.0
12.	Bulk density (g/cm ³)	<1.0	Less than 1.6
13.	Total organic carbon, % by weight, minimum	12.0	7.9
14.	Total nitrogen (N), % by weight, minimum	0.8	0.4
15.	Total phosphate (P ₂ O ₅), % by weight, minimum	0.4	10.4
16.	Total potassium (K ₂ O), % by weight, minimum	0.4	–
17.	Colour	Dark brown to black	–
18.	Odour	Absence of foul odour	–
19.	Particle size	Minimum 90% material should pass through 4.0 mm IS sieve	Minimum 90% material should pass through 4.0 mm IS sieve
20.	Conductivity (as dsm-1), not more than	4.0	8.2
<p>Note: Tolerance limits as per FCO: For compost- A sum total of nitrogen, phosphorus and potassium nutrients shall not be less than 1.5% in compost For PROM- No such directive</p>			

Source: Advisory on On-Site and Decentralized Composting of Municipal Organic Waste, SBM-U, MoHUA, 2018